

This copy is a reprint which includes current pages from Change 1.

DEPARTMENT OF THE ARMY TECHNICAL MANUAL

**Operator and Organizational Maintenance Manual
FLUTTER AND WOW METER ME-254/U**

**Headquarters, Department of the Army, Washington, D.C.
5 April 1971**

		Paragraph	Page
Chapter 1.	INTRODUCTION		
Section I.	General		
	Scope	1-1	1
	Indexes of publications	1-2	1
	Forms and records	1-3	1
Section II.	Description and Data		
	Purpose and use	1-4	1
	Circuit operation	1-5	1
	Technical characteristics	1-6	4
Chapter 2.	INSTALLATION		
	General	2-1	5
	Unpacking	2-2	5
	Checking unpacked equipment	2-3	5
	Installation	2-4	5
Chapter 3.	OPERATING INSTRUCTIONS		
Section I.	Operators Controls Indicators and Connectors		
	General	3-1	6
	Controls and Indicators	3-2	6
Section II.	Operation		
	Operating procedures	3-3	6
	Measuring wow and flutter	3-4	7
Chapter 4.	OPERATION AND ORGANIZATIONAL MAINTENANCE		
	Scope	4-1	8
	Preventive maintenance	4-2	8
	Cleaning	4-3	8
	Troubleshooting	4-4	8
Chapter 5.	SHIPMENT, LIMITED STORAGE, AND DEMOLITION OF EQUIPMENT TO PREVENT ENEMY USE		
Section I.	Shipment and Limited Storage		
	Preparation of equipment for shipment	5-1	9
	Limited Storage	5-2	9
Section II.	Demolition of Equipment to Prevent Enemy Use		
	Authority for demolition	5-3	9
Appendix A.	REFERENCES		A-1
B.	MAINTENANCE ALLOCATION		B-1

CHANGE }
NO. 1 }

HEADQUARTERS
DEPARTMENT OF THE ARMY
WASHINGTON, DC 17 November 1977

**Operator's and Organizational Manual
FLUTTER AND WOW METER ME-254/U
(NSN 6625-00-987-8527)**

Change No. 1 is current as of June 1977

TM 11-6625-670-12 1, 5 April 1971, is changed as follows:

The title is changed as shown above.

Page 1. Paragraph 1-3 is superseded as follows:

1-3. Forms and Records

a. Reports of Maintenance and Unsatisfactory Equipment. Maintenance forms, records, and reports which are to be used by maintenance personnel at all maintenance levels are listed in and prescribed by TM 38-750.

b. Report of Packaging Handling Deficiencies. Fill out and forward DD Form 6 (Packaging Improvement Report) as prescribed in AR 700-58/NAVSUPINST 4030.29/AFR 71-13/MCO P4030.29A, and DSAR 4145.8.

c. Discrepancy in Shipment Report (DISREP) (SF 361). Fill out and forward Discrepancy in Shipment Report (DISREP) (SF 361) as prescribed in AR 55-38/-NAVSUPINST 4510.33A/AFR 75-18/MCO P4610.19B and DSAR 4500.15.

1-3.1. Reporting of Errors

You can help improve this manual by calling attention to errors and by recommending improvements and stating your reasons for the recommendations. Your letter or DA Form 2028 (Recommended Changes to Publications

and Blank Forms) should be mailed direct to Commander US Army Electronics Command, ATTN: DRSEL-MA-Q, Fort Monmouth, New Jersey 07703. A reply will be furnished direct to you.

1-3.2. Reporting Equipment Improvement Recommendations (EIR)

EIR's will be prepared using DA Form 2407, Maintenance Request. Instructions for preparing EIR's are provided in TM 38-750, the Army Maintenance Management System. EIR's should be mailed direct to Commander, US Army Electronics Command, ATTN: DRSEL-MA-Q, Fort Monmouth, New Jersey 07703. A reply will be furnished direct to you.

1-3.3. Administrative Storage

Administrative storage of equipment issued to and used by Army activities shall be in accordance with TM 740-90-1.

1-3.4. Destruction of Army Electronics Materiel

Destruction of Army electronic materiel to prevent enemy use shall be in accordance with TM 750-2442.

Page 11. Appendix B is superseded as follows:

APPENDIX B MAINTENANCE ALLOCATION

Section I. INTRODUCTION

B-1. General

This appendix provides a summary of the maintenance operations for Flutter and Wow Meter ME-254/U. It authorizes categories of maintenance for specific maintenance functions on repairable items and components and the tools and equipment required to perform each function. This appendix may be used as an aid in planning maintenance operations.

B-2. Maintenance Function

Maintenance functions will be limited to and defined as follows:

a. Inspect. To determine the serviceability of an item by comparing its physical, mechanical, and/or electrical characteristics with established standards through examination.

b. Test. To verify serviceability and to detect incipient failure by measuring the mechanical or electrical characteristics of an item and comparing those characteristics with prescribed standards.

c. Service. Operations required periodically to keep an item in proper operating condition, i.e., to clean (decontaminate), to preserve, to drain, to paint, or to replenish fuel, lubricants, hydraulic fluids, or compressed air supplies.

d. Adjust. To maintain, Within prescribed limits, by bringing into proper or exact position, or by setting the operating characteristics to the specified parameters.

e. Align. To adjust specified variable elements of an item to bring about optimum or desired performance.

f. Calibrate. To determine and cause corrections to be made or to be adjusted on instruments or test measuring and diagnostic equipments used in precision measurement. Consists of comparisons of two instruments, one of which is a certified standard of known accuracy, to detect and adjust any discrepancy in the accuracy of the instrument being compared.

g. Install. The act of emplacing, seating, or fixing into position an item, part, module (component or assembly) in a manner to allow the proper functioning of the equipment or system.

h. Replace. The act of substituting a serviceable like type part, subassembly, or module (component or assembly) for an unserviceable counterpart.

i. Repair. The application of maintenance

services (inspect, test, service, adjust, align, calibrate, replace) or other maintenance actions (welding grinding, riveting, straightening, facing, remachining, or resurfacing) to restore serviceability to an item by correcting specific damage, fault, malfunction, or failure in a part, subassembly, module (component or assembly), end item, or system. This function does not include the trial and error replacement of running spare type items such as fuses, lamps, or electron tubes.

i. Overhaul. That maintenance effort (service/action) necessary to restore an item to a completely serviceable/operational condition as prescribed by maintenance standards (i.e., DMWR) in appropriate technical publications. Overhaul is normally the highest degree of maintenance performed by the Army. Overhaul does not normally return an item to like new condition.

k. Rebuild. Consists of those services/actions necessary for the restoration of unserviceable equipment to a like new condition in accordance with original manufacturing standards. Rebuild is the highest degree of materiel maintenance applied to Army equipment. The rebuild operation includes the act of returning to zero those age measurements (hours, miles, etc.) considered in classifying Army equipments/ components.

B-3. Column Entries

a. Column 1, Group Number. Column 1 lists group numbers, the purpose of which is to identify components, assemblies, subassemblies, and modules with the next higher assembly.

b. Column 2, Component/Assembly. Column 2 contains the noun names of components, assemblies, subassemblies, and modules for which maintenance is authorized.

c. Column 3, Maintenance Functions. Column 3 lists the functions to be performed on the item listed in column 2. When items are listed without maintenance functions, it is solely for purpose of having the group numbers in the MAC and RPSTL coincide.

d. Column, 4, Maintenance Category. Column 4 specifies, by the listing of a "work time" figure in the appropriate subcolumn(s), the lowest level of maintenance authorized to perform the function listed in column 3. This figure represents the active time required to perform that maintenance function

at the indicated category of maintenance. If the number or complexity of the tasks within the listed maintenance function vary at different maintenance categories, appropriate "worktime" figures will be shown for each category. The number of task-hours specified by the "worktime" figure represents the average time required to restore an item (assembly, subassembly, component, module, end item or system) to a serviceable condition under typical field operating conditions. This time includes preparation time, troubleshooting time, and quality assurance/quality control time in addition to the time required to perform the specific tasks identified for the maintenance functions authorized in the maintenance allocation chart. Subcolumns of column 4 are as follows:

- C - Operator/Crew
- O - Organizational
- F - Direct Support
- H - General Support
- D - Depot

e. *Column 5, Tools and Equipment.* Column 5 specifies by code, those common tool sets (not individual tools) and special tools, test, and support equipment required to perform the designated function.

f. *Column 6, Remarks.* Not applicable.

B-4. Tool and Test Equipment Requirements (Sect. III)

a. *Tool or Test Equipment Reference Code.* The numbers in this column coincide with the numbers used in the tools and equipment column of the MAC. The numbers indicate the applicable tool or test equipment for the maintenance functions.

b. *Maintenance Category.* The codes in this column indicate the maintenance category allocated the tool or test equipment.

c. *Nomenclature.* This column lists the noun name and nomenclature of the tools and test equipment required to perform the maintenance functions.

d. *National/NATO Stock Number.* This column lists the National/NATO stock number of the specific tool or test equipment.

e. *Tool Number.* This column lists the manufacturer's part number of the tool followed by the Federal Supply Code for manufacturers (5-digit) in parentheses.

B-4. Remarks (Sect IV)

Not applicable.

**SECTION II MAINTENANCE ALLOCATION CHART
FOR
FLUTTER AND WOW METER ME-254/U**

(1) GROUP NUMBER	(2) COMPONENT ASSEMBLY	(3) MAINTENANCE FUNCTION	(4) MAINTENANCE LEVEL					(5) TOOLS AND EQUIPMENT
			C	O	F	H	D	
00	METER, FLUTTER AND WOW ME-254/U	Inspect		0.1				
		Test				0.5		1-7
		Service		0.1				
		Adjust				0.3		1.7
		Calibrate				0.3		1.7
		Repair				0.3		1.7
		Overhaul					2.0	1-7

**SECTION III TOOL AND TEST EQUIPMENT REQUIREMENTS
FOR
FLUTTER AND WOW METER ME-254/U**

TOOL OR TEST EQUIPMENT REF CODE	MAINTENANCE CATEGORY	NOMENCLATURE	NATIONAL/NATO STOCK NUMBER	TOOL NUMBER
1	H, D	TRANSFORMER, VARIABLE	4931-00-777-1385	
2	H, D	GENERATOR, SIGNAL SG-621A/U	6625-00-606-9727	
3	H, D	VOLTMETER, ELECTRONIC ME-30/U	6625-00-643-1670	
4	H, D	COUNTER, ELECTRONIC AN/USM-207A	6625-00-044-3228	
5	H, D	OSCILLOSCOPE, AN/USM-281A	6625-00-228-2201	
6	H, D	TOOL KIT, ELECTRONIC EQUIPMENT TK-105/G	5180-00-610-8177	
7	H, D	RESISTOR, FIXED COMP 200 OHMS, 5%, 1/2 WATT	5905-00-279-2674	

By Order of the Secretary of the Army:

BERNARD W. ROGERS
General, United States Army
Chief of Staff

Official:

J. C. PENNINGTON
Brigadier General, United States Army
The Adjutant General

DISTRIBUTION:

Active Army:

USASA (2)
COE (D)
TSG (1)
USAARENBD (1)
DARCOM (1)
TECOM (2)
USACC (4)
TRADOC (2)
OS Maj Comd (4)
MDW (1)
Armies (2)
Corps (Z)
HISA (Ft Monmouth) (33)
Ft Gillem (10)
Ft Gordon (10)
Ft Huachuca (10)
Ft Carson (5)
Ft Richardson (ECOM Ofc) (2)
Svc Colleges (1)
USASIGS (5)
USAICS (3)
USAADS (3)
USAFAS (2)
USAARMS (2)

ARNG & USAR: None.

For explanation of abbreviations used, see AR 310-50.

USAIS (2)
USAES (2)
AD (1) except
SAAD (30)
LBAD (14)
TOAD(14)
SHAD (3)
USA Dep (1)
Sig Sec USA Dep (1)
Sig Dep (1)
MAAG (1)
USARMIS (1)
USAERDAA (1)
USAERDAW (1)
Sig FLDMS (1)
Units org under fol TOE:
11-95
11-96
11-117
11-127
11-500(AA-AC)
29-134
29-136
29-427

GPO 901-425

CHAPTER 1 INTRODUCTION

Section I. GENERAL

1-1. Scope

This manual provides operating and organizational maintenance for Meter, Flutter and Wow ME-254/U (fig. 1-1). It covers installation, operation, and operators maintenance. Cleaning and inspection of the equipment are included in the manual.

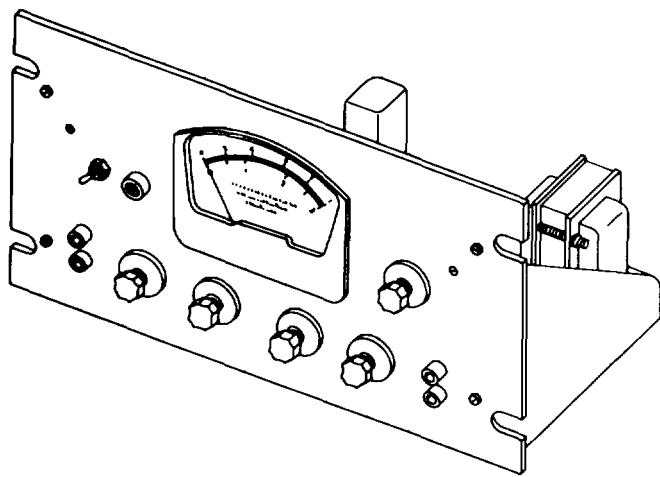

EL6625-670-12-TM-1

Figure 1-1. Meter, flutter and wow ME-254/U.

1-2. Indexes of Publications

Refer to the current issue of DA Pam 310-4 and DA Pam 310-7 to determine latest editions, changes, or additional publications pertaining to the equipment.

1-3. Forms and Records

a. *Reports of Maintenance and Unsatisfactory Equipment.* Use equipment records in accordance with instructions given in TM 38-750.

b. *Report of Packaging and Handling Deficiencies.* Fill out and forward DD Form 6 (Report of Packaging and Handling Deficiencies) as prescribed in AR 700-58 (Army)/NAVSUP Publication 378 (Navy)/AFR 71-4 (Air Force)/ and MCO P4610 (Marine Corps).

c. *Discrepancy in Shipment Report (DISREP) (SF 361).* Fill out and forward Discrepancy in Shipment Report (DISREP) (SF 361) as prescribed in AR 55-38 (Army)/NAVSUP Pub 459 (Navy)/AFM 75-34 (Air Force)/ and MCO P4610.19 (Marine Corps).

d. *Reporting of Equipment Manual Improvements.* Reporting of errors, omissions, and recommendations for improving this publication by the individual user is encouraged. Reports should be submitted on DA Form 2028 (Recommended Changes to Publications) and forwarded to Commanding General, U.S. Army Electronics Command, ATTN: AMSEL-ME-NMP-EM, Fort Monmouth, N.J. 07703.

Section II. DESCRIPTION AND DATA

1-4. Purpose and Use

The Meter, Flutter and Wow ME-254/U (hereafter called meter) is an extremely sensitive electronic measuring device, designed for measuring flutter and wow, which is defined as the ratio of the root mean square deviation in frequency of a standard recorded signal (3,000 Hz) to the average frequency, expressed as a percentage. It provides a rapid and accurate direct visual indication of flutter and wow content of all types of tape recorders and playback equipment including 33 1/3, 45, and 78 rpm discs and 8-, 16- and 35-mm soundfilm mechanisms. For research and development work, two output terminals are provided for analyzing the

characteristics of the flutter. The output terminals on the front panel are provided for oscilloscope display, and a test point mounted on the rear chassis apron provides dc response so that drift as well as wow and flutter may be recorded on a direct recorder with suitable amplifiers.

1-5. Circuit Operation

a. The circuit uses the basic principles involved in the detection of fm signals. This includes the use of a limiter amplifier to prevent the am components from producing an indication in the output circuits. Such am, for example, may be introduced by drop-

outs in the magnetic coating of recording tape, clicks and pops in records, and light fluctuations in photorecording. A frequency discriminator demodulates the flutter signals and presents them to an averaging-type meter circuit calibrated to read the root mean square value of sine wave modulation. Suitable filters

are provided to examine the wow and flutter spectra separately. A regulated power supply and an internal 3,000-Hz carrier oscillator complete the circuit sections. Figure 1-2 illustrates the function of the meter in block diagram form.

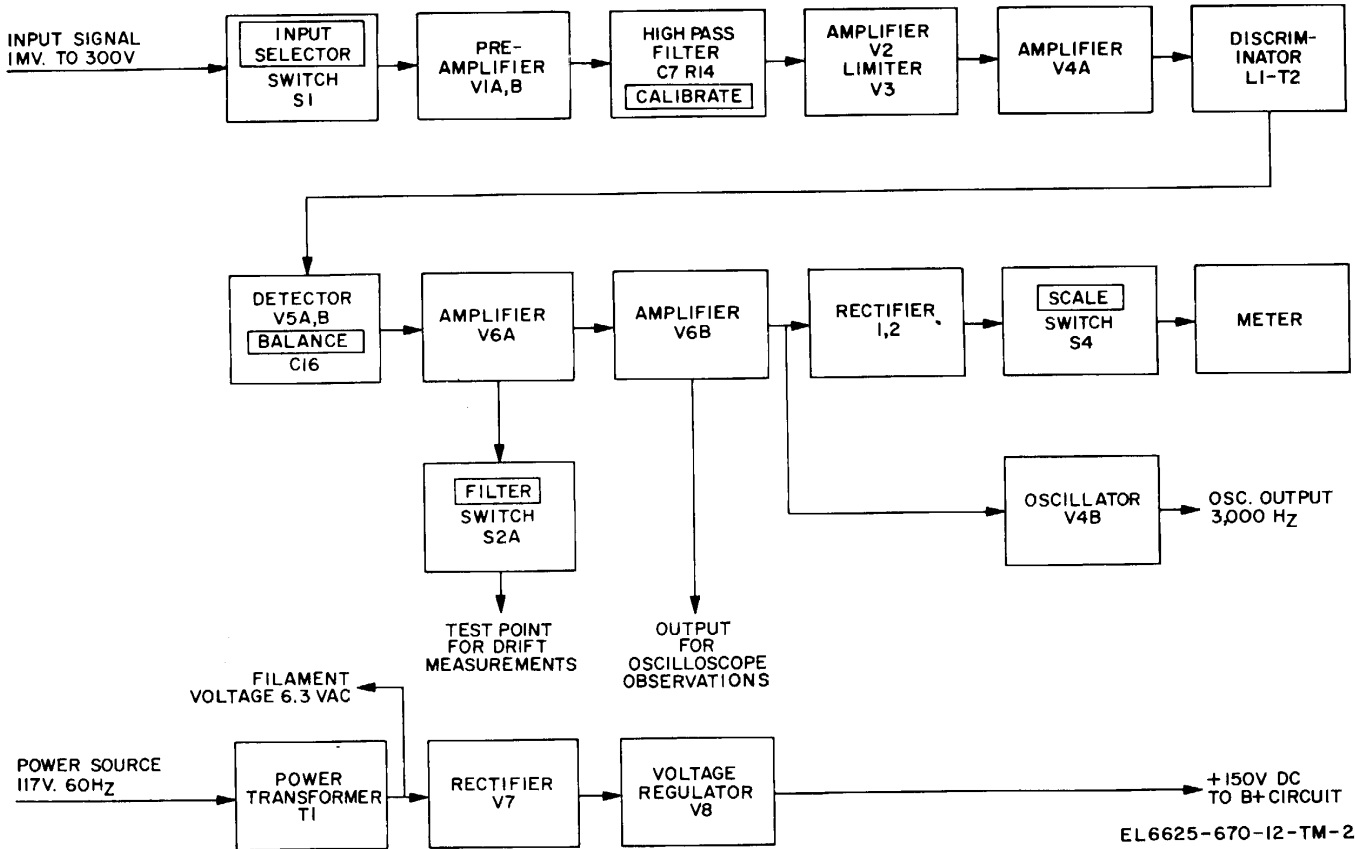

Figure 1-2. Meter, flutter and wow ME-254/U, functional block diagram.

b. The INPUT terminals are connected to an INPUT SELECTOR switch S1, which permits input acceptance signals in the range of 1 millivolt to 300 volts. The output of the INPUT SELECTOR switch is coupled to preamplifier V1, which permits coupling of a playback head direct to the INPUT terminals. This provides sufficient amplification to obtain a calibration reading on the meter, without the use of any external amplifier when only the output of a playback head is available. If the device under test contains a power amplifier or preamplifier, the INPUT SELECTOR switch is used to match the output voltage of the test unit.

c. The output of the preamplifier is coupled to a single section high-pass RC filter which connects to the CALIBRATE control. The function of the filter is to remove low frequency components from the carrier 3,000-Hz tone. This signal is amplified and fed into a symmetrical dual diode limiter V3. This circuit has been designed for symmetrical clipping of the signal to avoid introducing phase modulation of components on the main signal and to eliminate input level changes from affecting the accuracy of the meter readings.

d. The limited signal is amplified and fed into the pentode section of the V4A tube which acts as the amplifier for discriminator L1-T2. The detected flutter signal is taken from the detector V5 and passed through suitable filters to remove the carrier signal. A front panel control labeled "BALANCE", is provided to allow the discriminator to be tuned to the frequency of the incoming signal. The control will require adjustment when using a prerecorded signal which is being played back at a slightly different speed, resulting in off frequency operation. The band width of the discriminator is such that a flutter modulation signal of 250 Hz is attenuated no more than 3 db from a reference frequency of 75 Hz. Sufficient response is available to identify frequencies to 350 Hz with an oscilloscope.

e. The demodulated flutter signal is amplified by one of the triode sections of V6A and fed to the FILTER, selector switch which permits the wow, flutter, or overall wow plus flutter components to be measured. The cathode of this amplifier tube is also connected through an isolating resistor to the TEST POINT jack on the rear of the chassis for direct recording purposes. A small positive quiescent potential appears at this point which can be blocked off by the appropriate center controls on the direct recorder amplifier or by means of a low potential dc source. This dc output of the test point is valuable for drift measurements.

f. The filters separating the wow and flutter components consist of RC filters designed to give the

sharpest cutoff characteristics. The crossover frequency is 6 Hz. After the signal has passed through the filters it is again amplified and fed to a diode rectifier circuit. Full scale meter sensitivity of 3%, 1%, and 0.3%, are selected by the SCALE selector switch S4. The SCALE selector switch also provides a CAL position for calibrating the input signal for proper level settings and for connecting the meter across the discriminator BAL to indicate center frequency balance. Oscillator V4B provides the 3,000-Hz carrier.

g. The output of the oscillator is terminated on the rear of the chassis and is labeled "OSC OUTPUT". Approximately 2 volts ac is generated across an impedance of 250 ohms.

h. Regulated +150 volts dc is provided by voltage regulator V8 and provides stable operation over line voltage fluctuations of ±15 percent from 117 volt ac power source. Power transformer T1 operates on a 50- to 400 Hz input power frequency.

NOTE

The meter, FSN 6625-987-8527, comprises the entire operable instrument. One copy of TM 11-6625-670-12-1 is packed with each instrument.

1-6. Technical Characteristics

<i>Item</i>	<i>Characteristic</i>
Input voltage	0.001 to 300 volts
Input resistance	1 Megohm for all ranges, one side grounded
Range	0.01 to 3 percent
Full scale values	0.3, 1.0 and 3.0 percent
Accuracy	Within 2 percent of full scale reading
Filters (built-in)	0.5 to 6 Hz, 0.5 to 250 Hz, 6 to 250 Hz
Waveform effect	Accuracy independent of waveform
Limiter range	20db
Response rate	0 to 250 Hz
Oscillator (built-in)	3 000 Hz
Test frequency	3,000 Hz ±5 percent
Output terminals	For oscilloscope observation
Mounting	Standard rack panel
Size	8-3/4 inches high; 19 inches wide; 8 inches deep
Finish	Grey Hammertone
Operating current	105/125 volts, 50/400 Hz
Power consumption	30 watts
Model number	590-A-1
Net weight	12 pounds
Shipping weight	22 pounds

CHAPTER 2 INSTALLATION

2-1. General

This chapter contains information regarding the unpacking and installation of the meter.

2-2. Unpacking (fig. 2-1)

There are no special unpacking instructions required for the meter. Remove packing material and lift the equipment out carefully.

2-3. Checking Unpacked Equipment

Inspect equipment for damage which may have occurred during shipment. If the equipment has been

damaged, report the damage on DD Form 6 (para 1-3b). Check that equipment is complete as listed on the packing slip. Report all discrepancies in accordance with TM 38-750. Shortage of a minor assembly or part that does not affect proper functioning of the equipment should not prevent the use of the equipment.

2-4. Installation

No special instructions are required for installing the meter. An ac line cord is provided for connection to a 117-volt ac source with a frequency of 50 to 400 Hz.

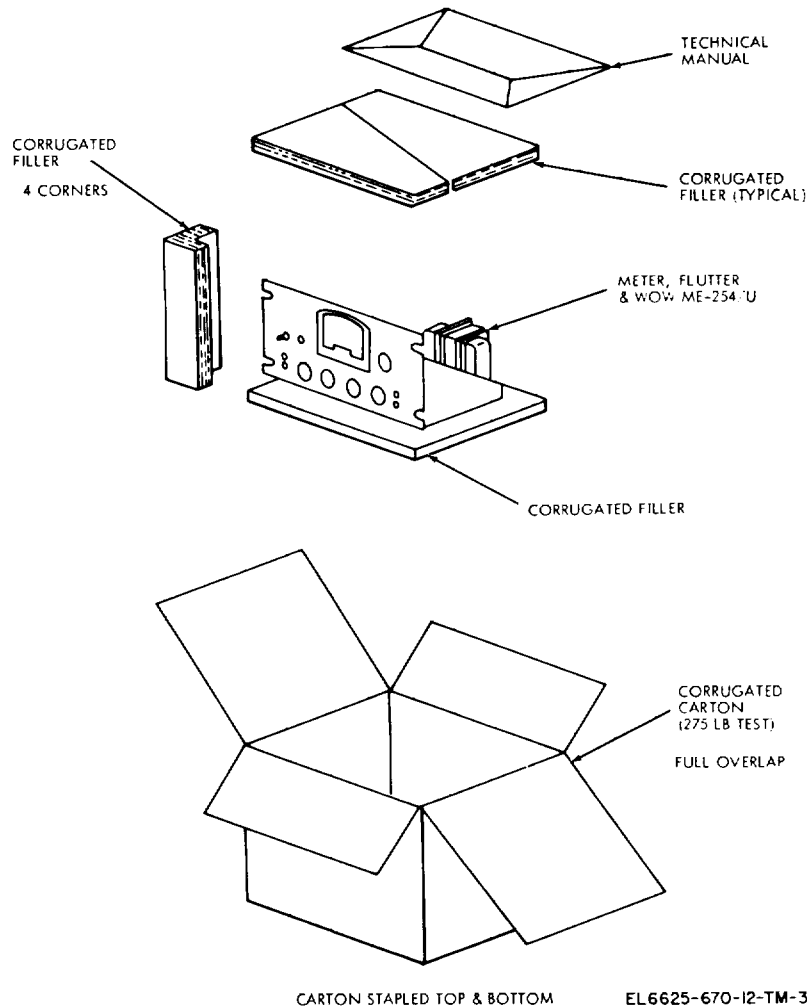

Figure 2-1. Packaging diagram.

CHAPTER 3
OPERATING INSTRUCTIONS

Section I. OPERATORS CONTROLS, INDICATORS, AND CONNECTORS

3-1. General

This section describes the purpose and use of all operating controls, indicators, and connectors. A view of the front panel is shown in figure 3-1. The panel markings and function of each operating control, indicator, and connectors are listed in paragraph 3-2.

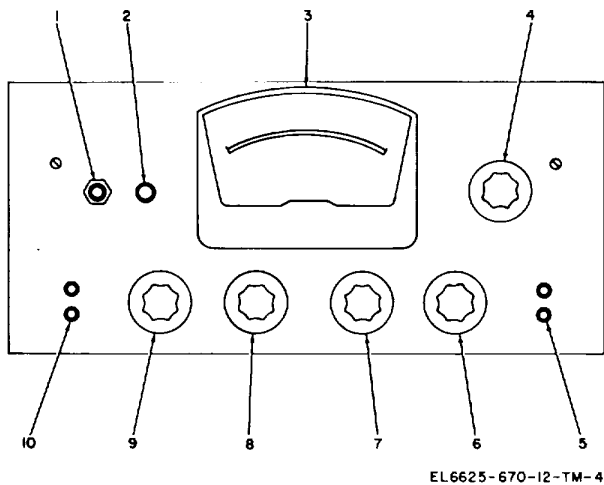

Figure 3-1. Front panel controls, indicators and connectors.

3-2. Controls and Indicators

Item No.	Control or indicator	Function
1	POWER ON-OFF switch	Placed in power input line to switch unit on or off.

Item No.	Control or indicator	Function
2	POWER ON lamp	Indicates that power is on when lamp is lighted.
3	Per cent flutter and wow meter	Provides visual indication of wow and flutter content of all types of tape recorders and playback equipment.
4	SCALE selector switch	a. Provides full scale meter sensitivities of 3.1 and 0.3 percent. b. Provides CAL position for calibrating input signal. c. Provides BAL position to indicate center frequency balance.
5	OUTPUT terminals	Provide output for oscilloscope observation of the flutter and wow characteristics.
6	FILTER selector switch	Permits the wow, flutter or overall wow plus flutter components to be measured.
7	BALANCE control	Tunes discriminator (L1-T2) to the frequency of the incoming signal.
8	CALIBRATE control	Provides adjustment for calibrating the input signal.
9	INPUT SELECTOR voltage switch	Provides voltage selection to match output voltage of test unit.
10	INPUT terminals	Accept input voltages from 1 millivolt to 300 volts.

Section II. OPERATION

3-3. Operating Procedures

a. The meter operates by measuring the degree of frequency modulation which is present on the 3,000-Hz carrier tone fed to the INPUT terminals. It is therefore necessary to produce a 3,000-Hz signal from the device under test.

b. With the usual tape recorder the output from the OSC OUTPUT terminals on the rear panel is fed to the input of the tape recorder and a 3,000-Hz signal

is recorded on the tape in the normal manner. The tape is then rewound and the output of the playback amplifier on the playback head is fed to the INPUT terminals of the meter. In this way, the flutter of both the tape recording process and the playback process of the particular device under test will be measured.

c. If a mechanism, with a playback head only is to be tested, a prerecorded tape containing a 3,000-Hz

tone with a known wow and flutter content must be used for test measurement. This test tape can be produced by recording the carrier tone from the OSC OUTPUT of the meter into a standard high quality recorder. The wow and flutter content contributed by the recorder should be measured with the wow and flutter meter and this amount subtracted from the overall meter reading of the unit under test.

3-4. Measuring Wow and Flutter

a. Starting.

(1) Turn on the meter and note that the POWER lamp glows.

(2) Allow approximately 60 seconds for tube warmup and stabilization.

(3) Connect the output of the device under test to the INPUT terminals of the meter.

b. Calibration.

(1) Set the SCALE selector switch to CAL.

(2) Set the INPUT SELECTOR, switch to 100 VOLTS.

(3) Rotate the CALIBRATE control to maximum clockwise position.

(4) Place device under test into operation. If flutter and wow meter does not indicate, rotate INPUT SELECTOR switch counterclockwise until a reading is obtained beyond the Cal. marking on the meter scale.

(5) Rotate the CALIBRATE control counterclockwise until the meter needle registers at the Cal. marking.

NOTE

If the output level from the device under test is lower than 1 millivolt and the meter needle does not deflect up to the Cal. marking but does indicate past the 0.1 mark on the top scale of the meter panel, sufficient limiter action is provided to obtain accurate flutter and wow measurements.

c. Balance.

(1) Set SCALE selector switch to BAL.

(2) Note meter reading, if needle deflects above zero, rotate BALANCE control counterclockwise in the DECREASE direction.

(3) If needle deflects below zero rotate BALANCE control clockwise in the INCREASE direction.

NOTE

The BALANCE control markings are relative and show only the direction of rotation since the control can be rotated approximately

ten full turns in any direction. Do not force the BALANCE control. Setting the BALANCE control to zero matches the discriminator to the frequency of the device under test.

d. Measurement.

(1) Rotate FILTER selector switch to 0.5-250 Hz. The meter will measure combined flutter and wow content of the unit under test.

(2) Rotate the SCALE selector switch to 3%.

NOTE

If the meter reading is below 3% rotate the SCALE selector switch to 1%. If below 1% rotate to 0.3% position.

(3) To measure flutter only, set the FILTER selector switch to 6-250 Hz.

(4) To measure wow only, set the FILTER selector switch to 0.5-6 Hz.

NOTE

Wow is defined as slow speed variation and usually falls in the range of 0.5 to 6 Hz per second. Flutter is defined as a fast speed variation and usually falls in the range of 6-250 Hz per second.

e. *Residual Meter Readings.* Due to the high sensitivity of the meter the panel meter needle will deflect if the INPUT terminals are open and the CALIBRATE control is turned to the maximum position. This is normally caused by extraneous signals which are picked up by the INPUT terminals and amplified. Those components within the band width of the flutter and wow meter are detected. This is indicated by a steady reading on the meter and when observed on an oscilloscope, a random evenly distributed noise spectrum is seen. The same effect occurs as a result of thermal emission present in the output amplifiers. When a signal is applied, the signal plus signal-to-noise ratio is such that only the flutter is indicated. This phenomenon is easily verified by observing the flutter signal with an oscilloscope and then removing the 3,000-Hz input signal, but still leaving the amplifiers connected to the INPUT terminals. Because of the relative broadband response of the flutter and wow meter, discriminating coil, and tuning range of the BALANCE control, it is possible to accept input signals varying as much as ± 5 percent away from the nominal or 3,000-Hz input frequency without affecting the readings by more than 5 percent.

CHAPTER 4 OPERATOR AND ORGANIZATIONAL MAINTENANCE

4-1. Scope

This chapter contains preventive maintenance procedures and instructions for cleaning, troubleshooting, repair, and adjustment.

4-2. Preventive Maintenance

Daily and weekly preventive maintenance procedures are required to maintain Army electronic equipment in combat serviceable condition. Records and reports of these procedures must be made in accordance with requirements of TM 38-750.

a. Daily Preventive Maintenance Procedures. The following procedures must be accomplished daily. They also must be accomplished when the equipment is initially installed or when the equipment is reinstalled after removal for any reason.

(1) Inspect for completeness and general condition of flutter and wow meter.

(2) Clean dirt and moisture from the exterior of meter case, including meter face, connectors, control knobs and switches.

(3) Observe that mechanical action of each knob and switch is smooth and free of external or internal binding.

(4) Insure that tubes are seated in their sockets properly.

b. Weekly Preventive Maintenance Procedures Services.

(1) Clean the interior of the flutter and wow meter case, including the exterior of components within the case.

(2) Inspect unit for frayed or broken wires and signs of arcing.

(3) Inspect the interior of the unit for corrosion.

(4) Inspect screws, nuts, and bolts for security.

4-3. Cleaning

Inspect the exterior of the unit. The exterior surfaces should be free of dust, dirt, grease and fungus.

(1) Remove dust and loose dirt with a clean, lint free cloth.

WARNING

Cleaning compound (FSN 7930-395-9542) is flammable and its fumes are toxic. Provide adequate ventilation. Do not use near a flame.

(2) Remove grease, fungus, and ground-in dirt with a cloth dampened (not soaked) in cleaning compound (FSN-7930-395-9542).

CAUTION

Do not press on the meter face (glass) when cleaning; the meter may be damaged.

(3) Clean the meter face with a soft, clean cloth. If dirt is difficult to remove, dampen cloth with water. Mild soap may be used for more effective cleaning.

4-4. Troubleshooting

If when properly installed (para 2-4), and operated (para 3-3) the meter fails to perform satisfactorily; refer to higher category of maintenance.

CHAPTER 5
SHIPMENT, LIMITED STORAGE, AND DEMOLITION OF EQUIPMENT
TO PREVENT ENEMY USE

Section I. SHIPMENT AND LIMITED STORAGE

5-1. Preparation of Equipment for Shipment

a. General. No detailed instructions for preparation of the meter are required. Refer to TM 38-230 for guidance container and crate construction.

b. Inspection. Inspect the meter for any unusual conditions such as damage, rusting, or pilferage. DA Form 2404 (Equipment Inspection and Maintenance

Worksheet) will be executed on equipment.

5-2. Limited Storage

No detailed instructions for preserving the equipment during limited storage are required. Equipment should be housed in a weatherproof area. Limited storage is defined as storage not to exceed 6 months.

Section II. DEMOLITION OF EQUIPMENT TO PREVENT ENEMY USE

5-3. Authority for Demolition

a. Demolition of the equipment will be accomplished only by order of the commander. The following destruction procedures will be used to prevent further use of the equipment.

b. Use any or all of the following methods to destroy the equipment.

(1) Smash the controls, tubes, coils, switches, and meters; use sledges, axes, handaxes, pickaxes, hammers, or crowbars.

(2) Cut and slash the wiring on the components; use axes, handaxes, or machetes.

WARNING

Be extremely careful with explosives and incendiary devices. Use these items only when the need is urgent.

(3) Burn technical manuals; use gasoline, kerosene, oil, flamethrowers, or incendiary grenades.

(4) Bend panels.

(5) If explosives are necessary, use firearms, grenades, or TNT.

(6) Bury or scatter the destroyed parts in slit trenches or foxholes, or throw them into streams.

APPENDIX A REFERENCES

The following publications are available to the operator and organizational maintenance personnel of the Meter, Flutter and Wow ME-254/U:

DA Pam 310-4	Index of Technical Manuals, Technical Bulletins, Supply Manuals, Supply Bulletins, and Lubrication Orders.
DA Pam 310-7	Index of Modification Work Orders.
SB 38-100	Preservation, Packaging, and Packing Materials, Supplies, and Equipment Used by the Army.
SB 11-573	Painting and Preservation Supplies Available for Field Use for Electronics Command Equipment.
TB 746-10	Field Instructions for Painting and Preserving Electronics Command Equipment.
TM 9-213	Painting Instructions for Field Use.
TM 38-750	Army Equipment Record Procedures.

**APPENDIX B
MAINTENANCE ALLOCATION**

Section I. INTRODUCTION

B-1. General

This appendix provides a summary of the maintenance operations covered in the equipment literature for Meter, Flutter and Wow ME-254/U. It authorizes categories of maintenance for specific maintenance functions on repairable items and components and the tools and equipment required to perform each function. This appendix may be used as an aid in planning maintenance operations.

B-2. Maintenance Functions

Maintenance functions will be limited to and defined as follows:

- a. *Inspect.* To determine serviceability of an item by comparing its physical, mechanical, and electrical characteristics with established standards.
- b. *Test.* To verify serviceability and to detect incipient electrical or mechanical failure by use of special equipment such as gages, meters, etc. This is accomplished with external test equipment and does not include operation of the equipment and operator type tests using internal meters or indicating devices.
- c. *Service.* To clean, to preserve, to charge, and to add fuel, lubricants, cooling agents, and air. If it is desired that elements, such as painting and lubricating, be defined separately, they may be so listed.
- d. *Adjust.* To rectify to the extent necessary to bring into proper operating range.
- e. *Align.* To adjust two or more components or assemblies of an electrical or mechanical system so that their functions are properly synchronized. This does not include setting the frequency control knob of radio receivers or transmitters to the desired frequency.
- f. *Calibrate.* To determine the corrections to be made in the readings of instruments or test equipment used in precise measurement. Consists of the comparison of two instruments, one of which is a certified standard of known accuracy, to detect and adjust any discrepancy in the accuracy of the instrument being compared with the certified standard.
- g. *Install.* To set up for use in an operational environment such as an encampment, site, or vehicle.
- h. *Replace.* To replace unserviceable items with serviceable like items.
- i. *Repair.* To restore an item to serviceable condition through correction of a specific failure or

unserviceable condition. This function includes, but is not limited to welding, grinding, riveting, straightening, and replacement of parts other than the trial and error replacement of running spare type items such as fuses, lamps, or electron tubes.

j. *Overhaul.* Normally, the highest degree of maintenance performed by the Army in order to minimize time work in process is consistent with quality and economy of operation. It consists of that maintenance necessary to restore an item to completely serviceable condition as prescribed by maintenance standards in technical publications for each item of equipment. Overhaul normally does not return an item to like new, zero mileage, or zero hour condition.

k. *Rebuild.* The highest degree of materiel maintenance. It consists of restoring equipment as nearly as possible to new condition in accordance with original manufacturing standards. Rebuild is performed only when required by operational considerations or other paramount factors and then only at the depot maintenance category. Rebuild reduces to zero the hours or miles the equipment, or component thereof, has been in use.

l. *Symbols.* The uppercase letter placed in the appropriate column indicates the lowest level at which that particular maintenance function is to be performed.

B-3. Explanation of Format

- a. *Column 1, Group Number.* Not used.
- b. *Column 2, Functional Group.* Column 2 lists the noun names of components, assemblies, subassemblies, and modules on which maintenance is authorized.
- c. *Column 3, Maintenance Functions.* Column 3 lists the maintenance category at which performance of the specific maintenance function is authorized. Authorization to perform a function at any category also includes authorization to perform that function at higher categories. The codes used represent the various maintenance categories as follows:

Code	Maintenance category
C.....	Operator/Crew
O.....	Organizational maintenance
F.....	Direct support maintenance
H.....	General support maintenance
D.....	Depot maintenance

d. *Column 4, Tools and Test Equipment.* Column 4 specifies, by code, those tools and test equipments required to perform the designated function. The numbers appearing in this column refer to specific tools and test equipment which are identified in table I.

e. *Column 5, Remarks.* Self-explanatory.

B-4. Explanation of Format of Table I, Tool and Test Equipment Requirements

The columns in table I are as follows:

a. *Tools and Equipment.* The numbers in this column coincide with the numbers used in the tools and equipment column of the maintenance allocation chart.

The numbers indicate the applicable tool for the maintenance function.

b. *Maintenance Category.* The codes in this column indicate the maintenance category normally allocated the facility.

c. *Nomenclature.* This column lists tools, test, and maintenance equipment required to perform the maintenance functions.

d. *Federal Stock Number.* This column lists the Federal stock number of the specific tool or test equipment.

e. *Tool Number.* Not used.

Section II. MAINTENANCE ASSIGNMENT

(1) Group No. a	(2) Component Assembly Nomenclature b	(3) Maintenance functions c											(4) Tools and equipment d	(5) Remarks e					
		A	B	C	D	E	F	G	H	I	J	K							
		Inspect	Test	Service	Adjust	Align	Calibrate	Install	Replace	Repair	Overhaul	Rebuild							
	ME-254/U Meter, Flutter, Wow FSN 6625-987-8527	O,C	..	O,C	5,6,7	Visual Clean
			H		H					D								4	Replace Tubes
								H										1,2,3,4	
																		1,2,4	
																		4	
																		1,2,3,4	

Section III. TOOL AND TEST EQUIPMENT REQUIREMENTS

Tool or test equipment reference code	Maintenance category	Nomenclature	FSN	Tool Number
H		Audio Oscillator, TS-421/U	6625-669-0228	
H		Meter Test Set TS-682/GSM-1	6625-669-0747	
H		Multimeter AN/URM-105	6625-581-2036	
H		Tool Kit TK-77/GF	5180-752-9068	
C, O		Cleaning compound	7930-395-9542	
C, O		Lint free cloth	8305-170-5062	
C, O		Small soft bristle brush	8020-245-4509	

By Order of the Secretary of the Army:

W. C. WESTMORELAND,
General, United States Army,
Chief of Staff.

Official:

VERNE L. BOWERS,
Major General, United States Army,
The Adjutant General.

Distribution:

Active Army:

CNGB (1)	WSMR (2)
Dir of Trans (1)	Fort Carson (7)
CofEngrs (1)	USAERDAA (2)
TSG (1)	USAERDAW (2)
CofSptS (1)	USACRREL (2)
ACSC-E (2)	Army Dep (1) except
USAMB (10)	LBAD (14)
USAARENBD (2)	SAAD (30)
USASA (2)	TOAD (14)
USACDC (2)	LEAD 7)
USACDCCEA (1)	ATAD (10)
USACDCCEA Ft Huachuca (1)	NAAD (3)
CONARC (2)	SVAD (3)
USAMC (1)	Gen Dep (1)
USAMICOM (2)	Sig Sec Gen Dep (5)
UTSATECOM (2)	Sig Dep (10)
USAMUCOM (2)	Sig FLDMS (1)
ARADCOM (2)	1st Cav Div (2)
ARADCOM Rgn (1)	Corps (2)
USAECOM (2)	Units org under fol TOE:
OS Maj Comd (2)	(1 copy each)
USACDCEC (10)	11-95
USASTRATCOM (2)	11-96
USAESC (70)	11-117
Armies (1)	11-127
USASCS (20)	11-158
USASESS (10)	11-500 (AA-AC)
Svc Colleges (1)	29-427
Fort Huachuca (5)	29-500

NG: None.

USAR: None.

For explanation of abbreviations used, see AR 310-50.

RECOMMENDED CHANGES TO EQUIPMENT TECHNICAL PUBLICATIONS



THEN... JOT DOWN THE DOPE ABOUT IT ON THIS FORM, CAREFULLY TEAR IT OUT, FOLD IT AND DROP IT IN THE MAIL!

SOMETHING WRONG WITH THIS PUBLICATION?

FROM: (PRINT YOUR UNIT'S COMPLETE ADDRESS)

DATE SENT

PUBLICATION NUMBER

PUBLICATION DATE

PUBLICATION TITLE

BE EXACT... PIN-POINT WHERE IT IS

PAGE NO.

PARA-GRAPH

FIGURE NO.

TABLE NO.

IN THIS SPACE TELL WHAT IS WRONG AND WHAT SHOULD BE DONE ABOUT IT:

TEAR ALONG PERFORATED LINE

PRINTED NAME, GRADE OR TITLE, AND TELEPHONE NUMBER

SIGN HERE:

DA FORM 2028-2 JUL 79

PREVIOUS EDITIONS ARE OBSOLETE.

P.S.—IF YOUR OUTFIT WANTS TO KNOW ABOUT YOUR RECOMMENDATION MAKE A CARBON COPY OF THIS AND GIVE IT TO YOUR HEADQUARTERS.

